



GSR-244L

Mini PLC with Display

USER MANUAL

GMT Industrial Electronics

Version 1.0 • May 2026

GETTING STARTED...

GSR-244L Mini PLC with Display

GMTCNT

This user manual contains the instructions for the GSR-244L Mini PLC with Display.

Before operating your device, please read and comply with this user manual! Retain it for future reference!

The user is responsible for any damage, loss, or personal injury arising from failure to comply with the warnings in this user manual. Faults occurring under such circumstances are not covered by the device warranty.

TABLE OF CONTENTS

Preface.....	4
CHAPTER I — GSR-244L MINI PLC WITH DISPLAY.....	5
1.1 Description.....	6
1.2 Advantages.....	6
1.3 General Structure.....	7
CHAPTER II — SPECIFICATIONS.....	8
2.1 General Specifications.....	9
2.2 Technical Specifications.....	9
2.3 Mechanical Specifications.....	11
CHAPTER III — MOUNTING, WIRING, AND INSTALLATION.....	12
3.1 Mounting.....	13
3.2 Wiring.....	17
3.3 Installation.....	18
CHAPTER IV — LOAD CELL CONNECTION.....	20
4.1 Terminal Structure.....	21
4.2 4-Wire Load Cell Connection.....	22
4.3 6-Wire Load Cell Connection.....	23
4.4 Connection Warnings.....	23
CHAPTER V — CONFIGURATION WITH GMT SUITE.....	24
5.1 How to Access GMT Suite.....	25
5.2 Configuration Sections.....	25
CHAPTER VI — MAINTENANCE AND SUPPORT.....	26
6.1 Maintenance.....	27
6.2 Device Warranty Instructions.....	27
6.3 Support.....	28
6.4 User Evaluation.....	28

Preface

GMT INDUSTRIAL ELECTRONICS CO. LTD. was founded to tackle challenges previously considered impossible in this region, to manufacture, and to market them. It is built upon over 30 years of expertise in industrial control, process control, and automation, and is entirely staffed by a technical team.

In addition to PLCs, Mini PLCs with Display and I/O modules — for which GMT holds 100% of the manufacturing and design technology — the company offers HMIs (Operator Panels), AC inverters, Servo Motors and Drives, Stepper Motors and Drives, and products with serial and RF communication capabilities, all developed to provide a complete solution.

GMT products are widely used in Food, Textile, Packaging, Extruder, Press, and Wood Machinery manufacturers, as well as in factory automation applications such as data acquisition, weighing, and remote monitoring.

Our products have proven themselves across the industry with their performance and quality.

GMT offers products with a high price-to-performance ratio to make its customers more competitive in the sector.

GMT will continue to invest in innovation and provide cost-effective, easy, and rapid solutions.

Edition: May 2026, Istanbul

Thank you for choosing the GMT CNT GSR-244L Mini PLC with Display.

We continuously develop and update the features of all our GMT CNT products, including our Mini PLC with Display, in line with your needs and requests.

GMTCNT

GSR-244L

CHAPTER

I

GSR-244L MINI PLC WITH DISPLAY

1 GSR-244L MINI PLC WITH DISPLAY

1.1 Description

The GSR-244L Mini PLC with Display is an electronic mini PLC device that controls a system via its inputs and outputs, with integrated timing, counting, storage, and arithmetic functions, and load cell (loadcell) support providing weight/force measurement and control capability.

The integrated display offers significant ease of use. The keypad on the device provides easy access to system configuration options. After creating a Ladder program suited to your needs, connecting the device to your computer is sufficient to run it.

The device features a single-channel internal measurement input with 24-bit resolution, compatible with 4-wire or 6-wire load cells. Weight and force measurement, calibration, stability control, tare, and zeroing operations are managed through the device. It can be used in weighing applications, filling and dosing systems, tension/compression force test setups, bulk inventory tracking systems, and similar industrial weighing applications.

Load cell configuration and calibration operations are performed through the GMT Suite editor software, via parameter addresses that can be used in the ladder program.

The GSR-244L Mini PLC with Display is economical and user-friendly thanks to its flexibility and performance.

1.2 Advantages

- Its display and keypad provide flexibility and ease of use.
- Its compact dimensions — designed with limited space in mind — allow it to be easily mounted in small cabinets, panels, and enclosures housing the control system.
- Its compact form significantly reduces wiring costs for systems.
- Provides precise weight measurement with a 24-bit high-resolution ADC.
- Compatible with both 4-wire and 6-wire load cells; the 6-wire connection compensates for voltage drop over long distances.
- Sensitivity can be selected in the range of 2 mV/V to 20 mV/V; compatible with all common load cells on the market.
- With a standard 2 ms sampling period and a maximum reading rate of 500 samples/second, it is suitable for dynamic weighing applications.
- Built-in isolation provides protection against electrical noise in industrial environments.
- Offers advanced configuration options such as 2-point and 3-point load calibration, mV/V-based equivalent input calibration, and gravity correction.
- Includes all essential functions required in weighing applications, such as digital filter, automatic zero tracking, stability detection, and under/over-range protection.
- Programmed with the advanced GMT Suite editor software. Features such as ladder logic, offline simulation, online simulation, and a graphic editor are available.
- Thanks to its structured design, easy and practical automation systems can be built without deep programming expertise.

1.3 General Structure

The general structure of the GSR-244L Mini PLC with Display is shown numerically in Figure 1 below.

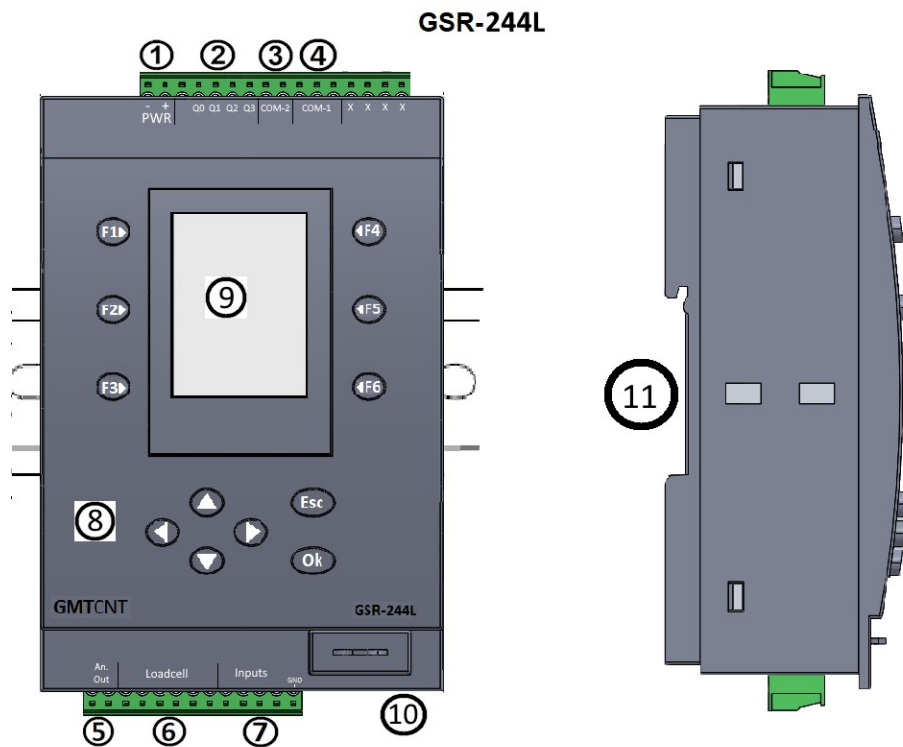

Figure 1 — Device structure

1. Power input
2. Relay outputs
3. COM2-RS485
4. COM1-RS232
5. Analog current output (0-20 mA / 4-20 mA)
6. Loadcell
7. Digital inputs
8. Control panel keypad
9. TFT LCD display
10. Programming socket housing
11. Mechanical rail adapter section



GSR-244L

CHAPTER



SPECIFICATIONS

2 SPECIFICATIONS

2.1 General Specifications

The GSR-244L Mini PLC with Display is designed for basic automatic control applications targeting weighing, dosing, force measurement, and similar precise measurement tasks in industrial environments.

1. 24 VDC Power Supply
2. 4-Channel Digital (NPN/PNP) Input + 1-Channel Load Cell (Loadcell) Input
3. 4-Channel Relay Output + 1-Channel Analog Current Output (0-20 mA / 4-20 mA)
4. 4-wire or 6-wire load cell support, 24-bit ADC, 2 mV/V – 20 mV/V sensitivity selection
5. 2-point, 3-point load calibration, and mV/V-based equivalent input (mV) calibration
6. Gravity correction, automatic zero tracking, tare, manual zeroing, stability detection, under/over-range protection
7. COM2-RS485 and COM1-RS232 serial communication ports (Modbus communication support)
8. Built-in 1.8-inch 128 (RGB) x 160 TFT LCD color display
9. Programmable keypad with 12 keys (6 on top, 6 on bottom) on the front face of the device, for user interface inputs
10. Easy testability of the 12-key keypad operation
11. Compatible with Windows 7 and later; easy to use with the "GMTSuite" programming interface (the "GMTSuite" editor software can be downloaded free of charge at <https://gmtcontrol.com/en/software/>)
12. Online input-output information available on the LCD display provides ease of operation, use, and maintenance
13. RTC (Real Time Clock) is included
14. Reverse polarity protection is provided
15. Short-circuit and overload protection is provided
16. Color display brightness can be adjusted from 100% to 10% in steps
17. Its compact dimensions allow easy installation in any limited space
18. DIN rail or panel mounting option available
19. Turkish / English language option available

2.2 Technical Specifications

Please note the following voltage tolerances, mains frequencies, and power consumption details.

1. Supply Voltage: 24 VDC ($\pm 10\%$ tolerance)
2. 4-Channel Digital (NPN/PNP) Input + 1-Channel Load Cell (Loadcell) Input
3. 4-Channel Relay Output + 1-Channel Analog Current Output (0-20 mA / 4-20 mA)
 - Relay Life (at 23 °C ambient temperature):
 - Mechanical: 5,000,000 operations min.
 - Electrical (resistive load): 100,000 operations at 250 VAC 5 A, 200,000 operations at 30 VDC 3 A (1,800 operations/hour at nominal load)
4. Maximum counting speed at digital inputs: 2 kHz (50% duty cycle)
5. Maximum program cycle speed: 20 kHz
6. 196 kB program memory area

7. Decimal operation support
8. Ladder Programming
9. Power Consumption: Maximum 3 W (peak current at power-on: 0.8 A)
10. Operating Temperature: 0 °C .. 50 °C
11. Storage Temperature: -10 °C .. 60 °C (non-condensing)
12. Relative Humidity: 80% up to 30 °C, then linearly decreasing to 50% at 50 °C
13. EMC: EN 61000-4-2, EN 61000-4-4, EN 61000-4-6
 - EN 61000-4-2: Electromagnetic compatibility, Electrostatic discharge (ESD) immunity test; ± 8 kV air discharge, 4 kV contact discharge
 - EN 61000-4-4: Electrical fast transient/burst immunity test; ± 4 kV (supply and signal input/output terminals), 5 kHz, 100 kHz
 - EN 61000-4-6: Surge immunity test; 500 V
14. Load Cell (Loadcell) Input specifications:
 - Load cell supply: 5 VDC, maximum 120 mA
 - Connection type: 4-wire or 6-wire
 - Sensitivity selection: 2 mV/V – 20 mV/V
 - Resolution: 24-bit
 - Standard sampling period: 2 ms
 - Maximum sampling rate: 500 samples/second
 - Built-in isolation
 - Warm-up time: ~30 minutes (recommended)
 - Calibration methods: 2-point, 3-point load calibration, and mV/V-based equivalent input calibration
 - Gravity (g) correction, automatic zero tracking, manual zeroing, tare, stability detection, under/over-range protection

2.3 Mechanical Specifications

- Mounting method: on 35 mm DIN rail (DIN EN 50022) or panel mounting
- Terminal tightening torque: maximum 0.56 N·m
- Cable cross-section: 0.5 mm² (20 AWG) – 1.5 mm² (16 AWG)
- Dimensions and weight: specified on the product label (standard GSR-series Mini PLC with Display dimensions)

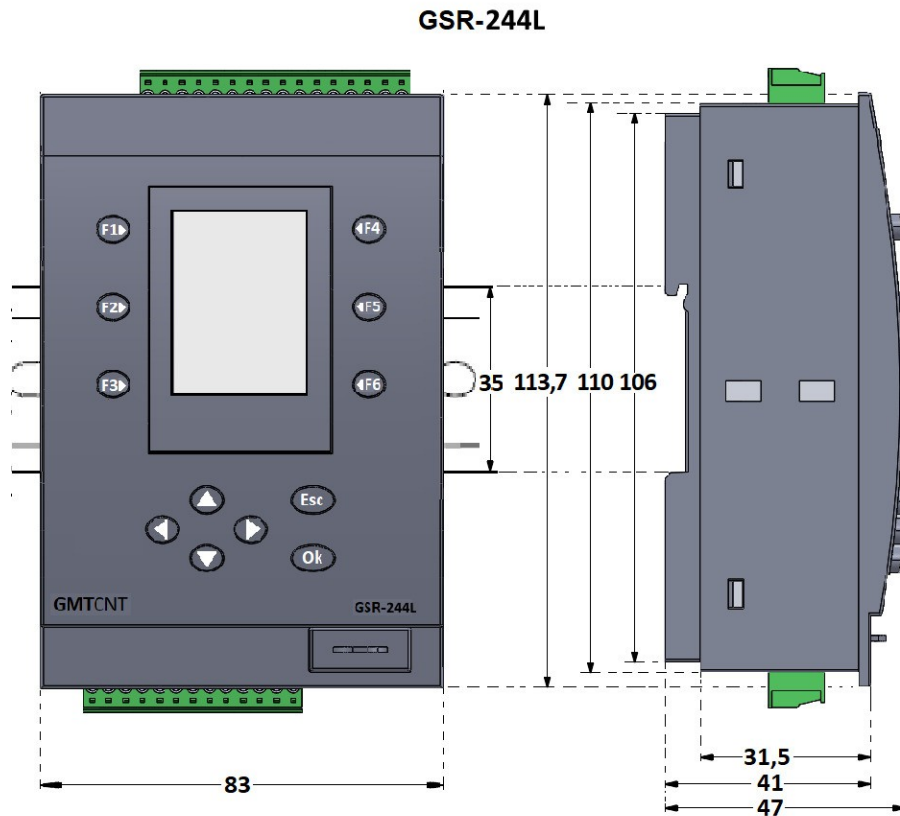

Figure 2 — Mechanical dimensions



GSR-244L

CHAPTER





MOUNTING, WIRING, AND INSTALLATION

3 MOUNTING, WIRING, AND INSTALLATION

3.1 MOUNTING

During mounting and dismantling;

 <p>Danger</p>	<p>Place the device on a non-flammable surface such as metal and keep it away from combustible materials. Otherwise, a fire may occur.</p> <p>Do not leave the mounting screws of the device loose.</p> <p>Do not drop wire fragments or screws into the device through the terminal openings; the device may be damaged.</p>
--	---

 <p>Caution</p>	<p>Mount the device in a location free from direct sunlight and vibration.</p> <p>When mounting more than two control devices in one cabinet, observe the recommended mounting distances for heat dissipation.</p>
---	--

The GMTCNT GSR-244L Mini PLC with Display is suitable for DIN rail mounting inside a control panel and panel mounting. The device can be mounted on a 35 mm rail compliant with DIN EN 50022 (automation rail). This section describes how to mount and dismantle the device.

3.1.1 Points to Consider During Mounting

- Always disconnect power when installing or removing the device. Take appropriate precautions to prevent unintended relay actuation. Establish the required grounding and short-circuit connections.
- Mount the device inside an electrical enclosure to protect it from rain and direct sunlight.
- Protect the device from combustible and flammable substances and materials.
- Mount the device securely on the panel rail via its connection points, in a location with adequate airflow and no obstruction of ventilation channels.
- Install the device with protection against adverse environmental conditions such as humidity, vibration, contamination, and high/low temperatures.
- Do not operate the device outside the technical specifications and environmental conditions specified in Chapter 2.

3.1.2 DIN Rail Mounting of the Device

To mount the device on the DIN rail, pull the fixing rail-clip downward and keep it retracted at its final position. Engage the grooved hook slot on the back of the device with the DIN rail; then push the clip upward to lock the device onto the DIN rail.

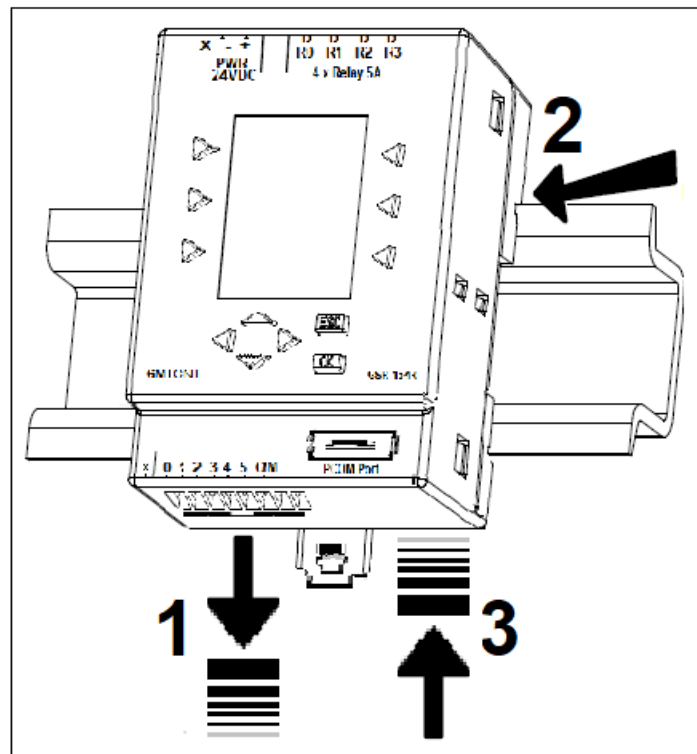

Figure 3 — DIN rail mounting

3.1.3 Removing the Device from the DIN Rail

Before removing the device, disconnect power.

- Pull the fixing rail-clip indicated by number 1 downward in steps to release the fixed device.
- At the point indicated by number 2, grasp the freed device and lift it upward to remove it.

3.1.4 Panel Mounting of the Device

When mounting the device on the panel, first ensure that the cutout in the panel is appropriate. For the device to fit properly in the panel as shown in Figure 4 below, the panel cutout must be 80×111 mm. The device's bearing cross-section resting against the panel is 79×110 mm as shown in Figure 4.

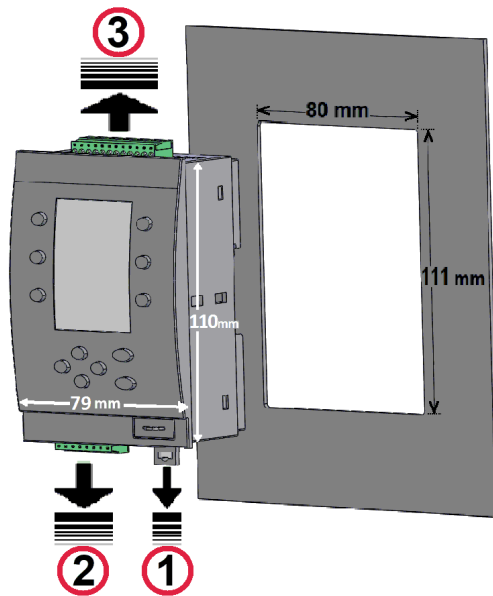

Figure 4 — Panel mounting

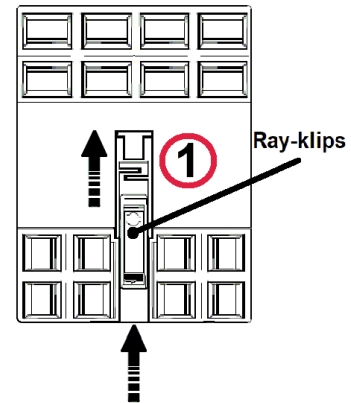

Figure 5 — Rear face of the device, rail-clip

- The factory-installed rail-clip on the rear face of the device, indicated by number 1, is removed.
- The factory-installed green input/output terminals on the top and bottom faces of the device, indicated by numbers 2 and 3, are removed.
- The device is placed onto the panel vertically.

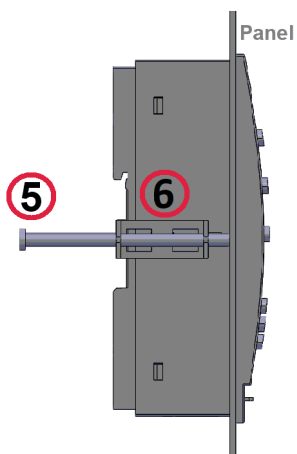

Figure 6 — Device profile

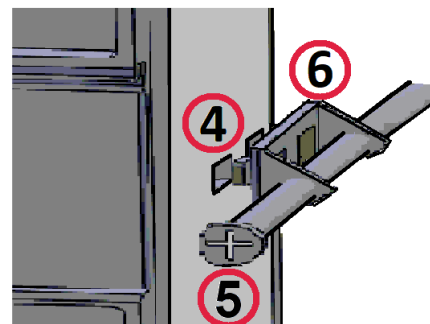

Figure 7 — Metal fixture entry point

- The dual-tooth metal fixing fixture indicated by number 6 is inserted into the twin metal tab slot located on the side faces of the device, indicated by number 4, so that the teeth engage the slots. These two metal fixtures are then firmly seated.
- The M4 metal YSB 60 mm screws indicated by number 5 are inserted through the twin holes on the handles of the dual-tooth metal fixtures indicated by number 6 and tightened using a screwdriver, securing the device to the panel.

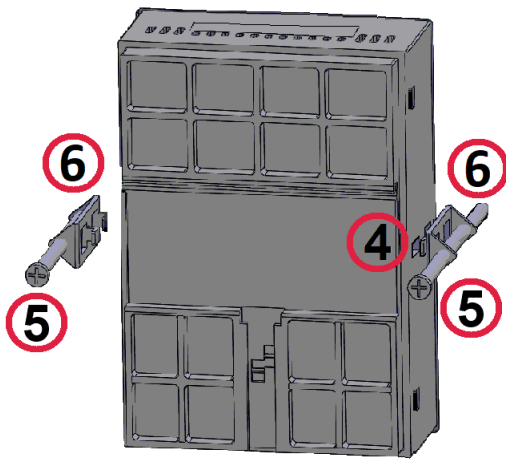

Figure 8 — Fixing the device to the panel

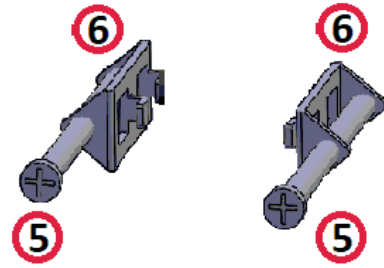

Figure 9 — Dual-tooth fixture, M4 YSB 60 mm screw

The device is locked into the panel as shown in Figure 10. The front and rear views after the device is panel-mounted are shown below. Finally, the input/output terminals indicated by numbers 2 and 3 are attached. Once power is supplied to the device, the PLC program is loaded and executed.

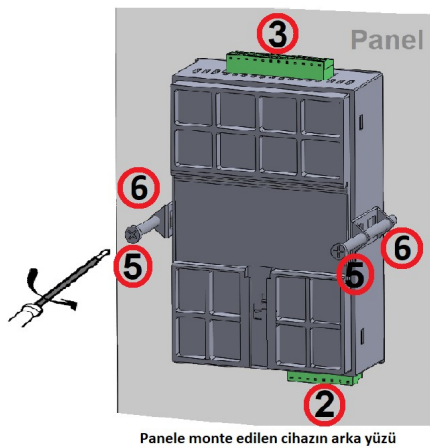

Figure 10 — Front and rear views after mounting

Number legend:

- 1: Rail-clip
- 2: Input terminal
- 3: Output terminal
- 4: Dual-tooth metal fixture slot
- 5: 60 mm M4 metal YSB screw
- 6: Dual-tooth metal fixing fixture

3.1.5 Removing the Device from the Panel

Before removing the device from the panel, disconnect power.

- The 60 mm M4 metal YSB screws (2 pieces) indicated by number 5 are removed using a screwdriver.
- The dual-tooth metal fixing fixtures (2 pieces) indicated by number 6 are pulled out of their slots. The freed device is grasped and removed by pulling it out from the front of the panel.

3.2 WIRING

During cable connection;

 Danger	<p>The device must be commissioned by qualified technical personnel. Otherwise, there is a risk of electric shock.</p> <p>Before connection, ensure that power is disconnected. Otherwise, there is a risk of electric shock.</p> <p>Ensure that the ground connection is properly made. Otherwise, there is a risk of electric shock.</p> <p>Follow the wiring warnings and connect the cables correctly. Otherwise, the device may be damaged.</p>
--	--

 Caution	<p>Ensure compliance with EMC and safety standards. Follow the instructions in this manual before wiring. Otherwise, there is a risk of injury or electric shock.</p> <p>The load cell must be connected using a shielded cable, and the cable shield must be properly grounded.</p>
---	--

3.2.1 Points to Consider During Wiring

Use a cable cross-section appropriate for the current drawn. Cable connections can be made with cables of up to 1.5 mm² cross-section. The cable cross-section range that can be inserted into the device terminals is 0.5 mm² (20 AWG) ~ 1.5 mm² (16 AWG). Table 1 below lists the minimum usable cable cross-section values.

Kablo Kesiti	Besleme 24VDC / Harici	Min :	0.37mm ² (AWG 21)
	Giriş / Çıkış	Digital Giriş	0.29mm ² (AWG 22) – 0.59mm ² (AWG 20)
		Digital Çıkış	0.033mm ² (AWG 32) – 0.066mm ² (AWG 29)
		Analog Giriş	0.0035mm ² (AWG 37)
		Analog Çıkış	0.0035mm ² (AWG 37)

Table 1 – Cable Cross-Section

Do not over-tighten the terminals. The maximum applicable torque is 0.56 N·m. The maximum torque applicable to input/output and supply terminals is specified in Table 2 below.

Vida Terminalleri Sıkma Torku	Besleme 24VDC / Harici	0.45 Nm (4lb-in)
	Giriş / Çıkış	0.56 Nm (5lb-in)

Table 2 – Tightening Torque for Screws

- Wiring should be kept as short as possible; if long cable runs are necessary, use shielded cables. The neutral connection should be routed together with the phase or signal wire (live conductor).

- AC cables, high-voltage DC cables, and low-voltage signal cables must be routed separately from each other.
- Ensure that the cables have adequate mechanical strength.
- Suitable surge protection must be installed on lines susceptible to lightning strikes.
- The device and its signal/communication cables must be kept away from equipment emitting electrical noise and from power-carrying lines. Shielded and twisted-pair signal and communication cables should be used, and the shield must be grounded at the device end.
- The load cell signal cable must be routed away from equipment emitting electrical noise, such as motors, contactors, and inverters.
- A suitable fuse should be used at the device's mains/supply input. Appropriate cabling should be used for mains connections.

3.3 INSTALLATION

3.3.1 Device Installation

During installation of the device;



Danger

Do not use flooded, damaged, or incomplete devices. Otherwise, there is a risk of damage.
Use insulation. Otherwise, there is a risk of electric shock.



Caution

Ensure the device is not damaged during transport. Do not use a control device that is damaged or missing parts, as this may cause injury.
Do not touch electronic parts and components, as this may cause static electricity.
Read the device's user manual thoroughly and carefully before use and installation.
Comply with the warnings in this manual. When performing the installation, mounting, and wiring of the device, ensure compliance with all applicable and mandatory standards.
Local/national regulations must be considered when installing and operating the devices.

3.3.2 GSR-244L Wiring Diagram

The digital inputs and outputs, load cell (loadcell), analog output, and communication ports must be connected as shown in the wiring diagram in Figure 11 below, according to the intended use. The green terminals on the device must be used for input and output connections.

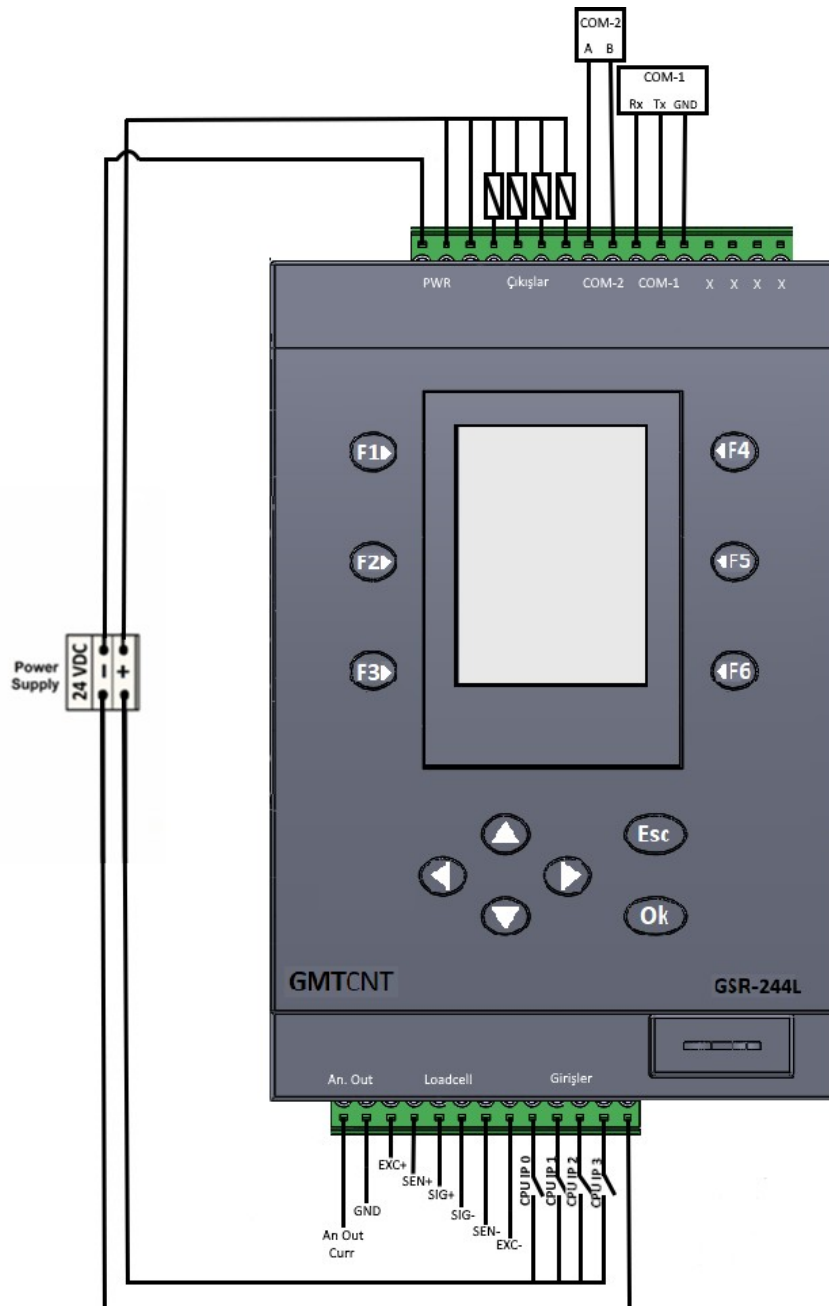

Figure 11 — Wiring Diagram

GMTCNT

GSR-244L

CHAPTER

IV

LOAD CELL CONNECTION

4 LOAD CELL CONNECTION

The GSR-244L Mini PLC with Display is compatible with 4-wire and 6-wire load cells. This chapter describes how to make both connection types and the points to consider during connection.

4.1 Terminal Structure

The load cell terminal on the device consists of terminals that supply power to the load cell and that read the feedback (sense) and bridge signal. The table below describes the functions of each terminal.

Terminal	Function	Description
EXC+	Positive supply	Terminal that supplies +5 VDC to the load cell.
EXC-	Negative supply	Negative supply (ground) terminal of the load cell.
SEN+	Positive sense (6-wire)	Positive supply feedback line read back from the load cell. Used in 6-wire connections.
SEN-	Negative sense (6-wire)	Negative supply feedback line read back from the load cell. Used in 6-wire connections.
SIG+	Positive signal	Positive output signal from the load cell bridge.
SIG-	Negative signal	Negative output signal from the load cell bridge.
SHLD	Shield	Terminal to which the cable shield braid is connected; routed to the ground path.

Not: Terminal labels appear on the device with similar abbreviations. Before wiring, verify the labeling on the device.

4.2 4-Wire Load Cell Connection

4-wire load cells have a total of four wires: two supply lines (EXC+, EXC-) and two signal lines (SIG+, SIG-). In a 4-wire connection, the sense terminals (SEN+, SEN-) are jumpered to EXC+ and EXC- on the device, so that the supply lines are read directly as the reference.

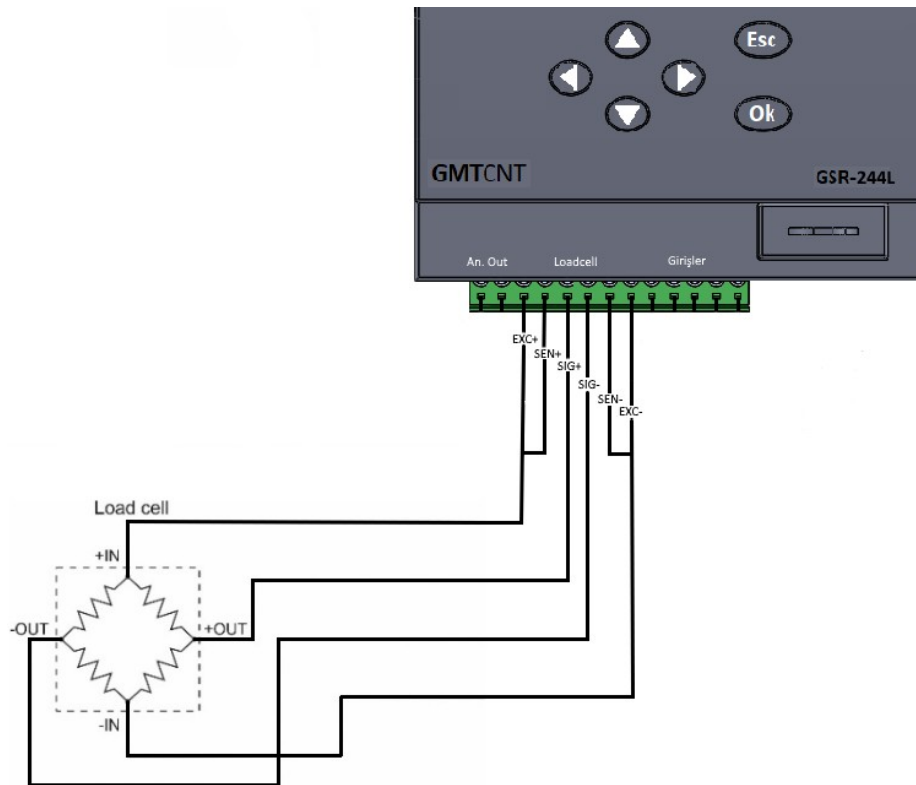

Figure 4 — 4-wire wiring diagram

1. Connect the EXC+ terminal to the load cell's positive supply wire (typically red) and the EXC- terminal to the negative supply wire (typically black).
2. Connect the SIG+ terminal to the load cell's positive signal wire (typically green) and the SIG- terminal to the negative signal wire (typically white).
3. Install jumpers on the device between SEN+ and EXC+, and between SEN- and EXC-.
4. Connect the load cell cable braid (shield) to the SHLD terminal.

4.3 6-Wire Load Cell Connection

6-wire load cells consist of two supply (EXC+, EXC-), two signal (SIG+, SIG-), and two sense (SEN+, SEN-) lines. The sense lines read back the actual supply voltage at the load cell side and compensate for voltage drop on long cables. For long distances (>~3 m) and applications requiring high accuracy, a 6-wire connection is recommended.

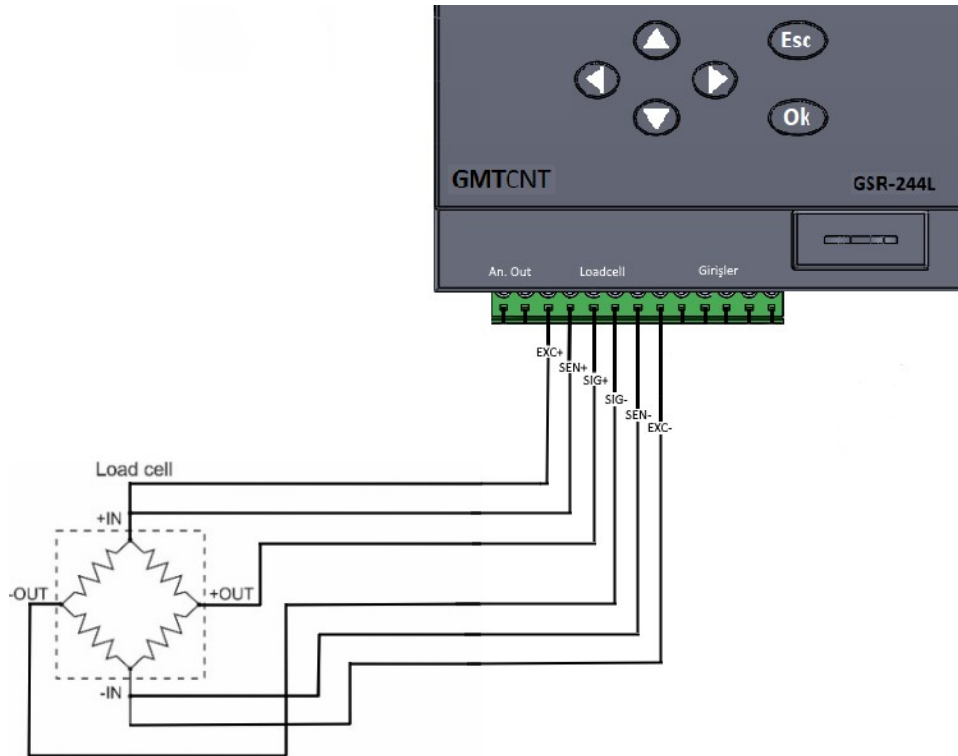

Figure 5 — 6-wire wiring diagram

1. Connect EXC+ / EXC- to the load cell's positive and negative supply wires.
2. Connect SIG+ / SIG- to the load cell's positive and negative signal wires.
3. Connect SEN+ / SEN- to the load cell's sense wires. Do not use jumpers in this connection.
4. Connect the load cell cable braid (shield) to the SHLD terminal.

4.4 Connection Warnings

Önemli: The load cell signal cable must be shielded and twisted pair.

The shield must be grounded at only one end, on the device side; grounding both ends may cause a ground loop.

When multiple load cells are used in parallel, a junction box must be used in accordance with the load cell manufacturer's instructions. The device expects a single bridge signal at its input.

After the connection is made, allow the device to warm up for at least 30 minutes before starting calibration.

GMTCNT

GSR-244L

CHAPTER

V

CONFIGURATION WITH GMT SUITE

5 CONFIGURATION WITH GMT SUITE

5.1 How to Access GMT Suite

On your computer, go to our company website at www.gmtcontrol.com and download the GMT Suite PLC Editor program, freely available under Downloads > Software. After completing the installation and wiring described in Chapters 3 and 4, apply power to your device.

By adding the GSR-244L device to the project tree in the GMT Suite editor, you can use the load cell parameter addresses, calibration triggers, and read values from your ladder program.

5.2 Configuration Sections

The configuration screen accessed via GMT Suite for the GSR-244L is divided into five main sections. Each section is accessed from the "Section" drop-down menu.

- Loadcell Parameters — basic measurement and behavior parameters of the load cell.
- Sensor Control — instantaneous measurement data, status flags, and trigger addresses used from the application.
- Load Calibration — calibration performed with a physical reference load (2 or 3-point).
- mV Calibration — equivalent input calibration using the mV/V values from the load cell certificate.
- Gravity Acceleration Correction — correction for the difference in gravity between the calibration and usage locations.

All parameters, default values, status codes, and step-by-step calibration examples for these five sections are described in detail in the device help documentation within GMT Suite.

GMTCNT

GSR-244L

CHAPTER

VI

MAINTENANCE AND SUPPORT

6 MAINTENANCE AND SUPPORT

During maintenance;



Danger

Do not repair or service the device while it is energized. Otherwise, there is a risk of electric shock.

Device maintenance and repair must be performed by trained technical personnel. Otherwise, injury and device damage may occur.

If the device is replaced, the parameter settings must be re-entered. After power is disconnected, all connections must be reestablished.

6.1 Maintenance

Temperature, humidity, dust, and vibration in the environment will cause aging of the components inside the device. This may cause the device to malfunction or reduce its service life. Therefore, routine and periodic maintenance of the device is required.

Maintenance should be performed in the following conditions:

1. If there is an abnormal sound during device operation,
2. If there is vibration during device operation,
3. If there is a change in the environmental conditions where the device is installed,
4. If the device has overheated,
5. If the load cell reading changes abruptly or is unstable.

Routine cleaning:

1. The device must always be kept clean.
2. Dust on the device must be cleaned. Metal dust in particular must be prevented from entering the device.
3. Check whether the load cell terminal contacts show signs of oxidation.

Periodic inspection:

1. Inspect the ventilation channels and keep them clean.
2. Check whether any panel-mounting screws are missing.
3. Check the cable connections for signs of arcing.
4. Verify that the shield connection of the load cell signal cable is correct.
5. Verify the calibration at regular intervals (at least once a year).

6.2 Device Warranty Instructions

GMT Industrial Electronics Co. Ltd. provides a 2-year warranty from the date of sale against damage occurring under the operating conditions specified in the user manual. Repairs for faults occurring outside this period are subject to a fee.

Repairs performed within the warranty period will be subject to a fee under the following conditions:

- Damage caused by use outside the conditions specified in the user manual,
- Damage caused by fire, flood, and mains-supply voltage fluctuations,
- Mechanical and electrical damage resulting from exceeding the maximum load cell capacity.

6.3 Support

For quick and easy answers to your questions regarding the Mini PLC with Display, please visit <http://forum.gmtcontrol.com>.

Technical support center contact information:

- Phone: +90 (216) 668 00 06, GSM: +90 (534) 363 75 33
- Fax: +90 (216) 668 00 08
- E-mail: gmt@gmtcontrol.com
- Address: Çubuklu Mh. Boğaziçi Cd. No:6/B Beykoz 34805 Istanbul, Turkey

6.4 User Evaluation

Dear Customer,

Reproduction or transmission of this user manual without the approval of company officials is prohibited. Those who do so are liable for any damages caused. In particular, all rights are reserved regarding patent rights or the emergence of a consumer product model or design.

This user manual has been reviewed for consistency with the hardware and software. Nevertheless, omissions may occur. However, the information in this user manual is regularly reviewed, and any necessary changes will be made in the next edition. You can contribute to a more user-friendly manual by providing your suggestions. We appreciate your contributions in this regard.